

MICHIGAN ELECTRIC UTILITY
Generator Interconnection Requirements

***Projects with
Aggregate Generator Output
of 30 kW or More, but Less than 150 kW***

Effective Aug. 10, 2004

INTRODUCTION

This Generator Interconnection Requirements document outlines the process, requirements, and agreements used to install or modify generation projects with aggregate generator output capacity ratings of 30 kW or more, but less than 150 kW, and designed to operate in parallel with the Utility electric system. Technical requirements (data, equipment, relaying, telemetry, metering) are defined according to type of generation, location of the interconnection, and mode of operation (Flow-back or Non-Flow-back). The process is designed to provide an expeditious interconnection to the Utility electric system that is both safe and reliable.

This document has been filed with the Michigan Public Service Commission (MPSC) and complies with rules established for the interconnection of parallel generation to the Utility electric system in the MPSC Order in Case No. U-13745.

The term “Project” will be used throughout this document to refer to a merchant plant and other electric generating equipment and associated facilities that are not owned or operated by an electric utility. The term “Project Developer” means a person that owns, operates, or proposes to construct, own, or operate, a Project.

This document does not address other Project concerns such as environmental permitting, local ordinances, or fuel supply. Nor does it address agreements that may be required with the Utility and/or the transmission provider, or state or federal licensing, to market the Project’s energy. An interconnection request does not constitute a request for transmission service.

It may be possible for the Utility to adjust requirements stated herein on a case-by-case basis. The review necessary to support such adjustments, however, may be extensive and interfere with study fees and the project schedule established by the MPSC and addressed in these requirements. Therefore, if requested by the Project Developer, adjustments to these requirements will only be considered if the Project Developer agrees in advance to compensate the Utility for the added costs of the necessary additional reviews and to also allow the Utility additional time for the additional reviews.

The Utility may apply for waiver from one or more provisions of these rules and the MPSC may grant a waiver upon a showing of good cause.

CONTENTS

THE INTERCONNECTION PROCESS	1
Interconnection Application	1
Interconnection Study	2
Interconnection and Operating Agreement.....	2
Project Design and Construction	2
Ongoing Operations	2
TECHNICAL REQUIREMENTS	3
Major Component Design Requirements	3
Data.....	3
Isolating Transformer(s).....	3
Isolation Device.....	3
Interconnection Lines.....	4
Relaying Design Requirements	4
Momentary Paralleling	4
Automatic Reclosing	4
Single-Phase Sectionalizing	5
Specific Requirements by Generator Type.....	6
Synchronous Projects	6
Induction Projects	6
Inverter-Type Projects.....	6
Relay Setting Criteria	6
Maintenance and Testing.....	6
Installation Approval.....	6
Miscellaneous Operational Requirements	7
Operating in Parallel	7
Reactive Power Control	8
Site Limitations.....	8
Revenue Metering Requirements	8
Non-Flow-back Projects.....	8
Flow-back Projects.....	9
Communication Circuits.....	9

CONTENTS

APPENDIX A	INTERCONNECTION APPLICATION
APPENDIX B	SYNCHRONOUS AND INDUCTION GENERATORS - REQUIRED DATA
APPENDIX C	INVERTER-TYPE GENERATORS - REQUIRED DATA
APPENDIX D	INTERCONNECTION STUDY AGREEMENT
APPENDIX E	INTERCONNECTION AND OPERATING AGREEMENT
APPENDIX F	CONTACT LIST

INTERCONNECTION PROCESS

The Interconnection Process

This section outlines the process for interconnecting 30 kW or more, but less than 150 kW of generation to the Utility electric system. This includes both new Projects and modifications to existing Projects. The general process is shown in Figure 1.

The Utility is required to complete all of its obligations for interconnection of the Project to the Utility system within 4 weeks from the time a complete Interconnection Application is received by the Utility.

A completed Interconnection Application consists of an application, data (Appendix B or C), and filing fee.

Delays that are the responsibility of Project Developer or attributable to the time lapse while the Utility diligently seeks to secure necessary rights-of-way, governmental permitting, zoning requirements, etc, will not be counted in the time to meet the 4 week deadline. The Utility shall have no responsibility to pursue court action to obtain these items.

Interconnection Application

The Project Developer must first submit an Interconnection Application to the Utility. A separate application is required for each Project or Project site. A blank Interconnection Application can be found in Appendix A. A list of the required interconnection data, depending on the capacity rating and type of generation, can be found in Appendices B and C.

A complete submittal of required interconnection data and filing fee of \$100 must accompany the Interconnection Application. The Utility will notify the Project Developer within 3 business days of receipt of an Interconnection Application. If any portion of the Interconnection Application, data submittal, or filing fee is incomplete and/or missing, the unapproved Interconnection Application will be sent back to the Project Developer with the deficiencies clearly identified.

Once the Utility has accepted an Interconnection Application, the Project is assigned a position in the Project queue maintained by the Utility. The Project position in the Project queue is determined by the date the Utility received the accepted Interconnection Application. The Utility will provide the Project Developer up to two hours of consultation related to the Project's interconnection to the Utility system and will include a good faith estimate of the Utility's charges to complete

Figure 1: The Interconnection Process

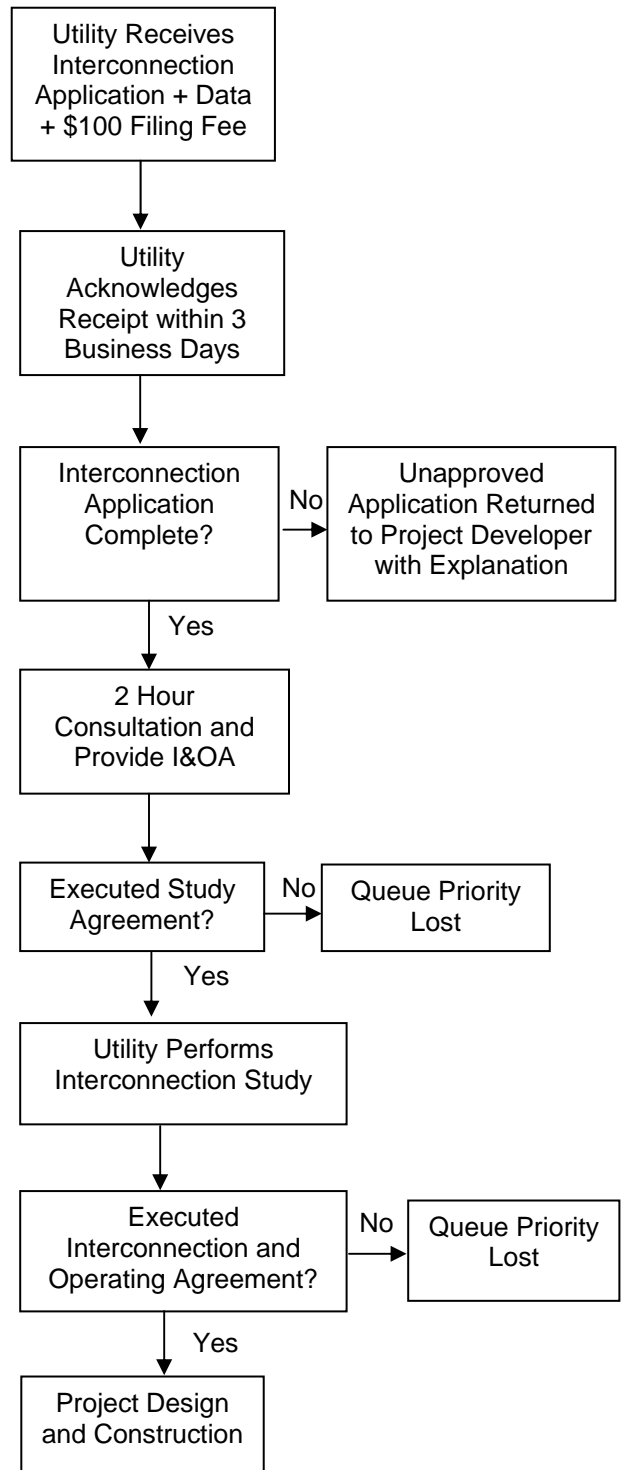

INTERCONNECTION PROCESS

the interconnection, including the estimated study fees, based on the information available to the Utility at that time.

Interconnection Study

The Utility will perform an Interconnection Study to determine the impact of the Project on the Utility's system, and the Utility's system modifications required for safe and reliable interconnection of the Project to the Utility system. The Project Developer is required to sign the Interconnection Study Agreement found in Appendix D and is encouraged to return the signed Interconnection Study Agreement to the Utility with the completed Interconnection Application to avoid delays in the interconnection process. Any delay in execution of the Interconnection Study Agreement will not toll the interconnection deadlines.

The Utility will charge the Project Developer for the costs associated with completion of the Interconnection Study. The costs will not exceed the lesser of either of the following:

- (1) Five percent of the estimated total cost of the Project, or
- (2) \$10,000

Interconnection Study fees are not required if the Interconnection Study determines that the Project's aggregate export capacity is less than 15% of the line section peak load and the project does not contribute more than 25% of the maximum short circuit current at the Point of Common Coupling (PCC) as defined by IEEE 1547.

Interconnection and Operating Agreement

The Utility will submit an Interconnection and Operating Agreement (I&OA) to the Project Developer, as soon as practical, after the 2 hour consultation described earlier. A sample Interconnection and Operating Agreement can be found in Appendix E.

The Interconnection and Operating Agreement will cover matters customarily addressed in such agreements in accordance with Good Utility Practice, including, without limitation, construction of facilities, system operation, interconnection cost and billing, defaults and remedies, insurance, and liability. All Utility costs, associated with making modifications to its distribution system, will be paid by the Project Developer.

Any delay in execution of the Interconnection and Operating Agreement will not count toward the interconnection deadlines.

Project Design and Construction

After the Interconnection and Operating Agreement is executed, the Utility will proceed to acquire necessary rights-of-way, procure required equipment, and design and construct the Interconnection Facilities.

Ongoing Operations

The Project Developer and Utility will exchange contact information and update this information from time to time. A sample Contact List can be found in Appendix F.

TECHNICAL REQUIREMENTS

Technical Requirements

The following discussion details the technical requirements for interconnection of Projects 30 kW or more, but less than 150 kW. For Projects within this capacity rating range, the Utility has made a significant effort to simplify the technical requirements. This effort has resulted in adoption of IEEE Std. 1547, Standard for Interconnecting Distributed Resources with Electric Power Systems, being incorporated herein by reference.

Certain requirements, as specified by this document, must be met to provide compatibility between the Project and the Utility's electric system, and to assure that the safety and reliability of the electric system is not degraded by the interconnection.

Upgraded revenue metering may be required for the Project.

Major Component Design Requirements

The data requested in Appendix B or C, for all major equipment and relaying proposed by the Project Developer, must be submitted as part of the initial application for review and approval by the Utility. The Utility may request additional data be submitted as necessary during the study phase to clarify the operation of the Project.

Once installed, the interconnection equipment must be reviewed and approved by the Utility prior to being connected to the Utility's electric system and before Parallel Operation is allowed.

Data

The data that the Utility requires to evaluate the proposed interconnection is documented on a "fill in the blank" checklist by generator type in Appendices B and C.

A site plan, one-line diagrams, and interconnection protection system details of the Project are required as part of the application data. The generator manufacturer data package should also be supplied.

Isolating Transformer(s)

If a Project Developer installs an isolating transformer, the transformer must comply with the current ANSI Standard C57.12.

The transformer should have high and/or low voltage windings sufficient to assure satisfactory generator operation over the range of voltage variation expected on the Utility electric system.

The type of generation and electrical location of the interconnection will determine the isolating transformer connections. Allowable connections are detailed in the "Specific Requirements by Generator Type" section. Note: Some Utilities do not allow an isolation transformer to be connected to a grounded Utility system with an ungrounded secondary (Utility side) winding configuration, regardless of the Project type. Therefore, the Project Developer is encouraged to consult with the Utility prior to submitting an application.

Isolation Device

An isolation device is required and should be placed at the Point of Common Coupling (PCC). It can be a circuit breaker, circuit switcher, pole top switch, load-break disconnect, etc., depending on the electrical system configuration. The following are required of the isolation device:

- Must be approved for use on the Utility system.
- Must comply with current relevant ANSI and/or IEEE Standards.

TECHNICAL REQUIREMENTS

- Must have load break capability, unless used in series with a three-phase interrupting device.
- Must be rated for the application.
- If used as part of a protective relaying scheme, it must have adequate interrupting capability. The Utility will provide maximum short circuit currents and X/R ratios available at the PCC, upon request.
- Must be operable and accessible by the Utility at all times (24 hours a day, 7 days a week).
- The Utility will determine if the isolation device will be used as a protective tagging point. If the determination is so made, the device must have visible open break provisions for padlocking in the open position and it must be gang operated. If the device has automatic operation, the controls must be located remote from the device.

Interconnection Lines

Any new line construction to connect the Project to the Utility's electric system will be undertaken by the Utility at the Project Developer's expense.

Relaying Design Requirements

Regardless of the technology of the interconnection, for simplicity for all projects in this capacity rating range, the interconnection relaying system must be certified by a nationally recognized testing laboratory to meet IEEE Std. 1547. The data submitted for review must include information from the manufacturer indicating such certification, and the manufacturer must placard the equipment such that a field inspection can verify the certification.

A copy of this standard may be obtained (for a fee) from the Institute of Electrical and Electronics Engineers (www.ieee.org).

Momentary Paralleling

For situations where the Project will only be operated in parallel with the Utility electric system for a short duration (100 milliseconds or less), as in a make-before-break automatic transfer scheme, no additional relaying is required. Such momentary paralleling requires a modern integrated Automatic Transfer Switch (ATS) system, which is incapable of paralleling the Project with the Utility's electric system. The ATS must be tested, verified and documented by the Project Developer for proper operation at least every 2 years. The Utility may be present during the testing.

Automatic Reclosing

The Utility employs automatic multiple-shot reclosing on most of the Utility's circuit breakers and circuit reclosers to increase the reliability of service to its customers. Automatic single-phase overhead reclosers are regularly installed on distribution circuits to isolate faulted segments of these circuits.

The Project Developer is advised to consider the effects of Automatic Reclosing (both single-phase and three-phase) to assure that the Project's internal equipment will not be damaged. In addition to the risk of damage to the Project, an out-of-phase reclosing operation may also present a hazard to Utility equipment since this equipment may not be rated or built to withstand this type of reclosing. The Utility will determine relaying and control equipment that needs to be installed to protect its own equipment from out-of-phase reclosing. Installation of this protection will be undertaken by the Utility at the Project Developer's expense.

In some cases, recloser settings can be modified to prevent out-of-phase reclosing. This could delay reclosing until the parallel generation is separated and the line is "de-energized". Hydraulic single-phase overhead recloser settings cannot be modified; therefore, these devices will have to be either replaced with three-phase overhead reclosers whose settings can be changed, or relocated beyond the Project

TECHNICAL REQUIREMENTS

location - depending upon the sectionalizing and protection requirements of the distribution circuit. If the Project can be connected to more than one circuit, these revisions may be required on the alternate circuit(s) as well.

Single-Phase Sectionalizing

The Utility also installs single-phase fuses and/or reclosers on its distribution circuits to increase the reliability of service to its customers. Three-phase generator installations may require replacement of fuses and/or single-phase reclosers with three-phase circuit breakers or circuit reclosers at the Project Developer's expense.

TECHNICAL REQUIREMENTS

Specific Requirements by Generator Type

Synchronous Projects

An isolation transformer will be required for three-phase Synchronous Projects. Except as noted below, the isolation transformer must be incapable of producing ground fault current to the Utility system; any connection except delta primary (Project side), grounded-wye secondary (Utility side) is acceptable. A grounded-wye - grounded-wye transformer connection is acceptable only if the Project's single line-to-ground fault current contribution is less than the Project's three-phase fault current contribution at the PCC. Protection must be provided for internal faults in the isolating transformer; fuses are acceptable.

For a sample One-Line Diagram of this type of facility, see Appendix B.

Induction Projects

For three-phase installations, any isolation transformer connection is acceptable except grounded-wye (Utility side), delta (Project side). Protection must be provided for internal faults in the isolating transformer; fuses are acceptable. In cases where it can be shown that self excitation of the induction generator cannot occur when isolated from the Utility, the Utility may waive the requirement that the generator provide protection for Utility system ground faults.

For a sample One-Line Diagram of this type of facility, see Appendix B.

Inverter-Type Projects

No isolation transformer is required between the generator and the secondary distribution connection. If an isolation transformer is used for three-phase installations, any isolation transformer connection is acceptable except grounded-wye (Utility side), delta (Project side). Protection must be provided for internal faults in the isolating transformer; fuses are acceptable.

If the inverter has passed a certified anti-island test, the Utility may waive the requirement that the Project Developer provide protection for the Utility system ground faults.

For a sample One-Line Diagram of this type of facility, see Appendix C.

Relay Setting Criteria

The relay settings for Projects 30 kW or more, but less than 150 kW must conform to the values specified in IEEE Std. 1547.

Maintenance and Testing

The Utility reserves the right to test the relaying and control equipment that involves protection of the Utility electric system whenever the Utility determines a reasonable need for such testing exists.

The Project Developer is solely responsible for conducting proper periodic maintenance on the generating equipment and its associated control, protective equipment, interrupting devices, and main Isolation Device, per manufacturer recommendations.

Routine Maintenance checks of the relaying and control equipment must be conducted in accordance with provided written test procedures which are required by IEEE Std. 1547, and test reports of such testing shall be maintained by the Project Developer and made available for Utility inspection upon request. [NOTE – IEEE 1547 requires that testing be conducted in accordance with written test procedures, and the nationally recognized testing laboratory providing certification will require that such test procedures be available before certification of the equipment.]

Installation Approval

The Project Developer must provide the Utility with 5 business days advance written notice of when the Project will be ready for inspection, testing, and approval.

TECHNICAL REQUIREMENTS

Prior to final approval for Parallel Operation, the Utility reserves the right to inspect the Project and receive action to assure conformance to the requirements stated herein.

Miscellaneous Operational Requirements

Miscellaneous requirements include synchronizing equipment for Parallel Operation, reactive requirements, and system stability limitations.

Operating in Parallel

The Project Developer will be solely responsible for the required synchronizing equipment and for properly synchronizing the Project with the Utility electric system.

Voltage fluctuation at the PCC during synchronizing is limited by IEEE Std. 1547.

These requirements are directly concerned with the actual operation of the Project with the Utility:

- The Project may not commence parallel operation until approval has been given by the Utility. The completed installation is subject to inspection by the Utility prior to approval. Preceding this inspection, all contractual agreements must be executed by the Project Developer.
- The Project must be designed to prevent the Project from energizing into a de-energized Utility line. The Project's circuit breaker or contactor must be blocked from closing in on a de-energized circuit.
- The Project shall discontinue parallel operation with a particular service and perform necessary switching when requested by the Utility for any of the following reasons:
 1. When public safety is being jeopardized.
 2. During voltage or loading problems, system emergencies, or when abnormal sectionalizing or circuit configuration occurs on the Utility system.
 3. During scheduled shutdowns of Utility equipment that are necessary to facilitate maintenance or repairs. Such scheduled shutdowns shall be coordinated with the Project.
 4. In the event there is demonstrated electrical interference (i.e. Voltage Flicker, Harmonic Distortion, etc.) to the Utility's customers, suspected to be caused by the Project, and such interference exceeds then current system standards, the Utility reserves the right, at the Utility's initial expense, to install special test equipment as may be required to perform a disturbance analysis and monitor the operation and control of the Project to evaluate the quality of power produced by the Project. In the event that no standards exist, then the applicable tariffs and rules governing electric service shall apply. If the Project is proven to be the source of the interference, and that interference exceeds the Utility's standards or the generally accepted industry standards, then it shall be the responsibility of the Project Developer to eliminate the interference problem and to reimburse the Utility for the costs of the disturbance monitoring installation, removal, and analysis, excluding the cost of the meters or other special test equipment.
 5. When either the Project or its associated synchronizing and protective equipment is demonstrated by the Utility to be improperly maintained, so as to present a hazard to the Utility system or its customers.
 6. Whenever the Project is operating isolated with other Utility customers, for whatever reason.

TECHNICAL REQUIREMENTS

7. Whenever the Utility notifies the Project Developer in writing of a claimed non-safety related violation of the Interconnection Agreement and the Project Developer fails to remedy the claimed violation within ten working days of notification, unless within that time either the Project Developer files a complaint with the MPSC seeking resolution of the dispute or the Project Developer and Utility agree in writing to a different procedure.

If the Project has shown an unsatisfactory response to requests to separate the generation from the Utility system, the Utility reserves the right to disconnect the Project from parallel operation with the Utility electric system until all operational issues are satisfactorily resolved.

Reactive Power Control

Synchronous generators that will operate in the Flow-back Mode must be dynamically capable of providing 0.90 power factor lagging (delivering reactive power to the Utility) and 0.95 power factor leading (absorbing reactive power from the Utility) at the Point of Receipt. The Point of Receipt is the location where the Utility accepts delivery of the output of the Project. The Point of Receipt can be the physical location of the billing meters or a location where the billing meters are not located, but adjusted for line and transformation losses.

Induction and Inverter-Type generators that will operate in the Flow-back Mode must provide for their own reactive needs (steady state unity power factor at the Point of Receipt). To obtain unity power factor, the Induction or Inverter-Type Project can:

1. Install a switchable Volt-Ampere reactive VAR supply source to maintain unity power factor at the Point of Receipt; or
2. Provide the Utility with funds to install a VAR supply source equivalent to that required for the Project to attain unity power factor at the Point of Receipt at full output.

There are no interconnection reactive power capability requirements for Synchronous, Induction, and Inverter-Type Projects that will operate in the Non-Flow-back Mode. The Utility's existing rate schedules, incorporated herein by reference, contain power factor adjustments based on the power factor of the metered load at these facilities.

Site Limitations

The Project Developer is responsible for evaluating the consequences of unstable generator operation or voltage transients on the Project equipment, and determining, designing, and applying any relaying which may be necessary to protect that equipment. This type of protection is typically applied on individual generators to protect the Projects.

The Utility will determine if operation of the Project will create objectionable voltage flicker and/or disturbances to other Utility customers and develop any required mitigation measures at the Project Developer's expense.

Revenue Metering Requirements

The Utility will own, operate, and maintain all required billing metering equipment at the Project Developer's expense.

Non-Flow-back Projects

A Utility meter will be installed that only records energy deliveries to the Project.

TECHNICAL REQUIREMENTS

Flow-back Projects

Special billing metering will be required. The Project Developer may be required to provide, at no cost to the Utility, a dedicated dial-up voice-grade circuit (POTS line) to allow remote access to the billing meter by the Utility. This circuit shall be terminated within ten feet of the meter involved.

The Project Developer shall provide the Utility access to the premises at all times to install, turn on, disconnect, inspect, test, read, repair, or remove the metering equipment. The Project Developer may, at its option, have a representative witness this work.

The metering installations shall be constructed in accordance with the practices, which normally apply to the construction of metering installations for residential, commercial, or industrial customers. For Projects with multiple generators, metering of each generator may be required. When practical, multiple generators may be metered at a common point provided the metered quantity represents only the gross generator output.

The Utility shall supply to the Project Developer all required metering equipment and the standard detailed specifications and requirements relating to the location, construction, and access of the metering installation and will provide consultation pertaining to the meter installation as required. The Utility will endeavor to coordinate the delivery of these materials with the Project Developer's installation schedule during normal scheduled business hours.

The Project Developer may be required to provide a mounting surface for the metering equipment. The mounting surface and location must meet the Utility's specifications and requirements.

The responsibility for installation of the equipment is shared between the Utility and the Project Developer. The Project Developer may be required to install some of the metering equipment on its side of the PCC, including instrument transformers, cabinets, conduits, and mounting surfaces. The Utility shall install the meters and communication links. The Utility will endeavor to coordinate the installation of these items with the Project Developer's schedule during normal scheduled business hours.

Communication Circuits

The Project Developer is responsible for ordering and acquiring the telephone circuit required for the Project Interconnection. The Project Developer will assume all installation, operating, and maintenance costs associated with the telephone circuits, including the monthly charges for the telephone lines and any rental equipment required by the local telephone provider. However, at the Utility's discretion, the Utility may select an alternative communication method, such as wireless communications. Regardless of the method, the Project Developer will be responsible for all costs associated with the material and installation, whereas the Utility will be responsible to define the specific communication requirements.

The Utility will cooperate and provide Utility information necessary for proper installation of the telephone circuits upon written request.

All telephone circuits (both voice and data) must be analog circuits.

APPENDIX A

INTERCONNECTION APPLICATION

GENERATOR INTERCONNECTION APPLICATION

AGGREGATE GENERATOR OUTPUT OF 30 kW OR MORE, BUT LESS THAN 150 kW

1. The undersigned Project Developer submits this Generator Interconnection Application and appropriate filing fee to interconnect a new Project to the Utility Electric System or to increase the capacity of an existing Project connected to the Utility Electric System.
2. A Project Developer requesting interconnection or an increase in the capacity of an existing Project to the Utility Electric System must provide the following information:
 - a. Completed Interconnection Application Data sheet appropriate for the capacity rating and type of generating unit(s), as found in the Utility's Generator Interconnection Requirements (Interconnection Application Data sheet, found in Appendix B or C, must be attached to this Interconnection Application).
 - b. Description of the equipment configuration and proposed interconnection one-line diagram (one-line diagram must be attached to this Interconnection Application).
 - c. Project Developer (Single Point of Contact):

Name: _____

Address: _____

Phone Number: _____

Fax Number: _____

e-mail Address: _____

Project Site Address: _____

3. This Generator Interconnection Application shall be directed to the Utility representative as indicated below:

We Energies
Attn: Jason Kollwelter
231 W. Michigan St. - P318
Milwaukee, WI 53203

4. I, the undersigned and authorized representative of the Project, submit this Generator Interconnection Application and required technical data for the Utility. I understand that upon acceptance, the Utility shall subsequently provide an Interconnection Study Agreement, if said Interconnection Study is determined to be necessary. The Interconnection Study Agreement will include the Scope of the Interconnection Study. I also understand that I shall be required to furnish certain required technical data as requested by the Utility in support of this study and reimburse the Utility for its study expenses.

Authorized Signature: _____

Printed Name: _____

Title: _____

Company Name: _____

Date: _____

APPENDIX B

**SYNCHRONOUS AND INDUCTION
GENERATORS**

**AGGREGATE GENERATION OF 30 kW OR
MORE, BUT LESS THAN 150 kW**

REQUIRED DATA

**ONE-LINE REPRESENTATION
TYPICAL ISOLATION AND FAULT PROTECTION FOR SYNCHRONOUS GENERATOR INSTALLATIONS
30 kW OR LARGER, BUT LESS THAN 150 kW**

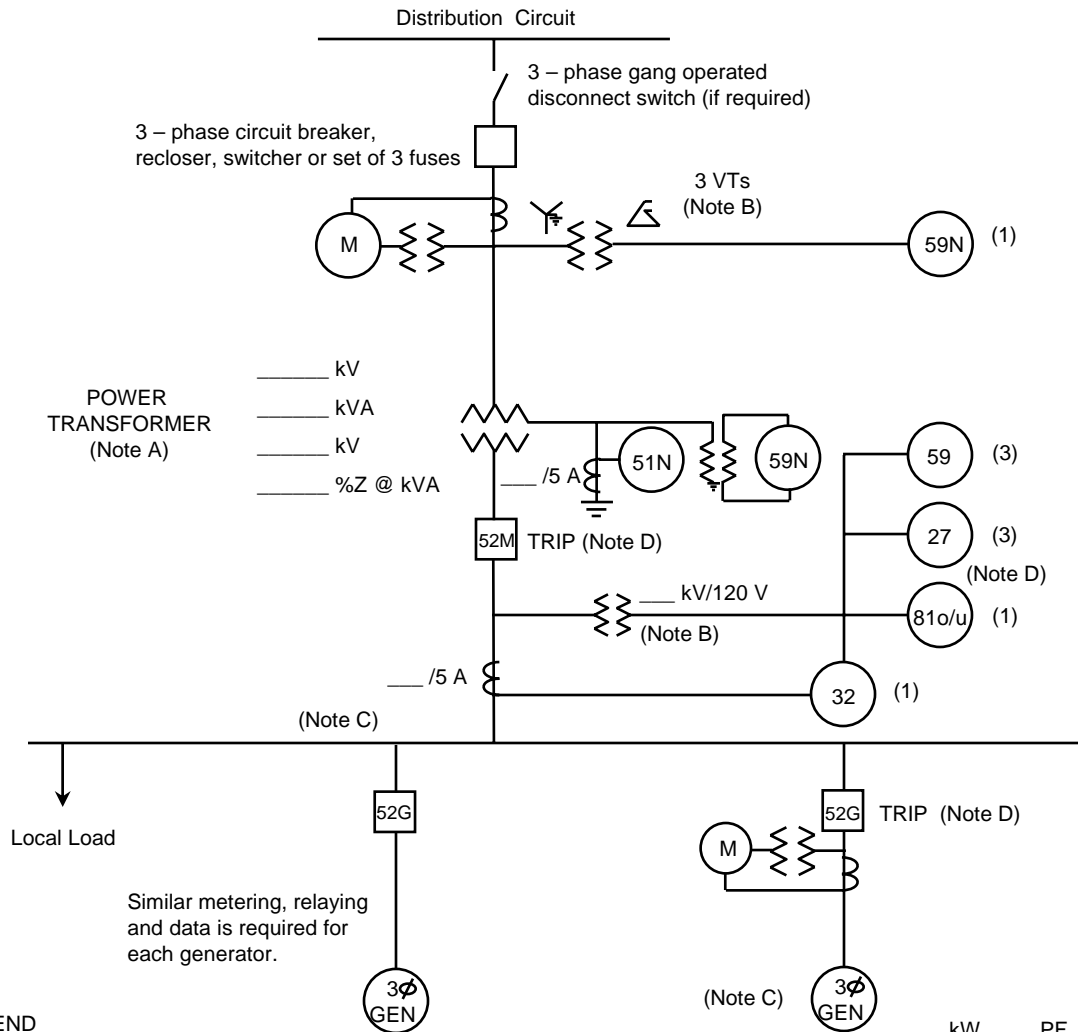

LEGEND

<p>27 Undervoltage</p> <p>32 Reverse Power (not required for sellback)</p> <p>51N Neutral overcurrent (required for grounded secondary)</p> <p>59 Overvoltage</p> <p>59N Zero sequence overvoltage (assuming ungrounded secondary on power transformer)</p> <p>81o/u Over/Underfrequency</p>	<p>____ kW ____ PF ____ kV</p> <p>$X_d'' = \text{____ \% @ ____ kVA}$</p> <p>$X_d' = \text{____ \% @ ____ kVA}$</p> <p>$X_d = \text{____ \% @ ____ kVA}$</p>
--	---

NOTES

- A) See technical requirements for permissible connection configurations and protection. Transformer connections proposed shall be shown on the one-line diagram by the Project Developer. Transformer connection and secondary grounding to be approved by Utility.
- B) Protection alternatives for the various acceptable transformer connections are shown. Only one protection alternative will ultimately be used, depending on the actual transformer winding connections. VTs for 59, 27, 81o/u and 32 are shown connected on the primary (Project side) of the power transformer, but may instead be connected on the secondary (Utility side). VTs are required on the secondary of the power transformer if a 59N is required for an ungrounded secondary connection. IEEE std 1547 requirements for voltage and frequency must be met at the PCC. IEEE Std. 1547 permits the VTs to be connected at the point of generator connection in certain cases.
- C) Main breaker protection, generator protection and synchronizing equipment are not shown.
- D) Trip of all 52G breakers or the 52M breaker is acceptable, depending upon whether the Project Developer wants to serve its own isolated load after loss of Utility service.

**ONE-LINE REPRESENTATION
TYPICAL ISOLATION AND FAULT PROTECTION FOR INDUCTION GENERATOR INSTALLATIONS
30 kW OR LARGER, BUT LESS THAN 150 kW**

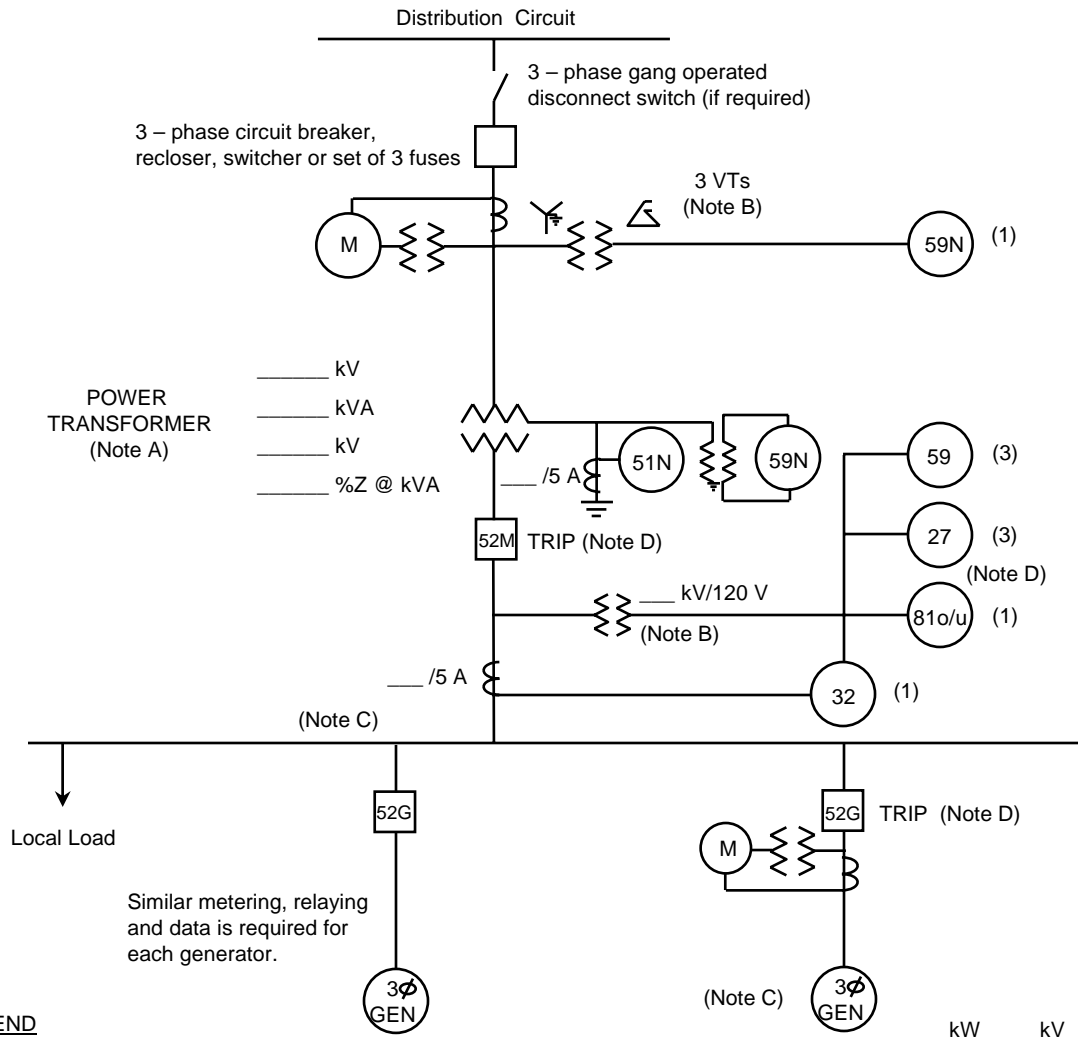

LEGEND

- 27 Undervoltage
- 32 Reverse Power (not required for sellback)
- 51N Neutral overcurrent (required for grounded secondary)
- 59 Overvoltage
- 59N Zero sequence overvoltage (assuming ungrounded secondary on power transformer)
- 81o/u Over/Underfrequency

NOTES

- A) See technical requirements for permissible connection configurations and protection. Transformer connections proposed shall be shown on the one-line diagram by the Project Developer. Transformer connection and secondary grounding to be approved by Utility.
- B) Protection alternatives for the various acceptable transformer connections are shown. Only one protection alternative will ultimately be used, depending on the actual transformer winding connections. VTs for 59, 27, 81o/u and 32 are shown connected on the primary (Project side) of the power transformer, but may instead be connected on the secondary (Utility side). VTs are required on the secondary of the power transformer if a 59N is required for an ungrounded secondary connection. IEEE std 1547 requirements for voltage and frequency must be met at the PCC. IEEE Std. 1547 permits the VTs to be connected at the point of generator connection in certain cases.
- C) Main breaker protection, generator protection and synchronizing equipment are not shown.
- D) Trip of all 52G breakers or the 52M breaker is acceptable, depending upon whether the Project Developer wants to serve its own isolated load after loss of Utility service.

**SYNCHRONOUS OR INDUCTION GENERATORS - AGGREGATE \geq 30 kW,
 BUT $<$ 150 kW
 INTERCONNECTION APPLICATION DATA FOR: _____
 PROVIDED BY: _____ DATE: _____**

Instructions: Attach data sheets as required. Indicate in the table below the page number of the attached data on which the requested information is provided.

General Information

Item No	Data Description	Attached Page No
1	Flow-back or Non-Flow-back	
2	Project Type (Base load, peaking, intermediate)	
3	Site Plan	
4	Simple One-Line Diagram(s) for Project and Project Load	
5	Detailed One-Line Diagram(s) for Project	
6	Energization Date for Project Interconnection Facilities	
7	First Parallel Operation Date for Testing	
8	Project Commercial Operation Date	
9	Estimated Project Cost	

The following information on these system components shall appear on the preliminary One-Line Diagram, including manufacturer make and model for the items listed below:

- Breakers - Rating, location and normal operating status (open or closed)
- Buses - Operating voltage
- Capacitors - Size of bank in kVAR
- Current Transformers - Overall ratio, connected ratio
- Fuses - normal operating status, rating (Amps), type
- Generators - Capacity rating (kVA), location, type, method of grounding
- Grounding Resistors - Size (ohms), current (Amps)
- Isolating transformers - Capacity rating (kVA), location, impedance, voltage ratings, primary and secondary connections and method of grounding
- Potential Transformers - Ratio, connection
- Reactors - Ohms/phase
- Relays - Types, quantity, IEEE device number, operator lines indicating the device initiated by the relays
- Switches - Location and normal operating status (open or closed), type, rating
- Tagging Point - Location, identification

**SYNCHRONOUS OR INDUCTION GENERATORS - AGGREGATE \geq 30 kW,
BUT $<$ 150 kW**

INTERCONNECTION APPLICATION DATA FOR: _____
PROVIDED BY: _____ DATE: _____

Instructions: Attach data sheets as required. Indicate in the table below the page number of the attached data (manufacturer's data where appropriate) on which the requested information is provided. Provide one table for each unique generator.

Electric Generator(s) at the Project			Generator No _____
Item No	Data Value	Data Description	Attached Page No
1		Generator Type (synchronous or induction)	
2		Generator Nameplate Voltage	
3		Generator Nameplate Watts or Volt-Amperes	
4		Generator Nameplate Power Factor (pf)	
5		Direct axis reactance (saturated)	
6		Direct axis transient reactance (saturated)	
7		Direct axis sub-transient reactance (saturated)	
8		Short Circuit Current contribution from generator at the Point of Common Coupling (single-phase and three-phase	
9		National Recognized Testing Laboratory Certification	
10		Written Commissioning Test Procedure	

APPENDIX C

INVERTER-TYPE GENERATORS AGGREGATE GENERATION OF 30 kW OR MORE, BUT LESS THAN 150 kW

REQUIRED DATA

**ONE-LINE REPRESENTATION
TYPICAL ISOLATION AND FAULT PROTECTION FOR INVERTER GENERATOR INSTALLATIONS
30 kW OR LARGER, BUT LESS THAN 150 kW**

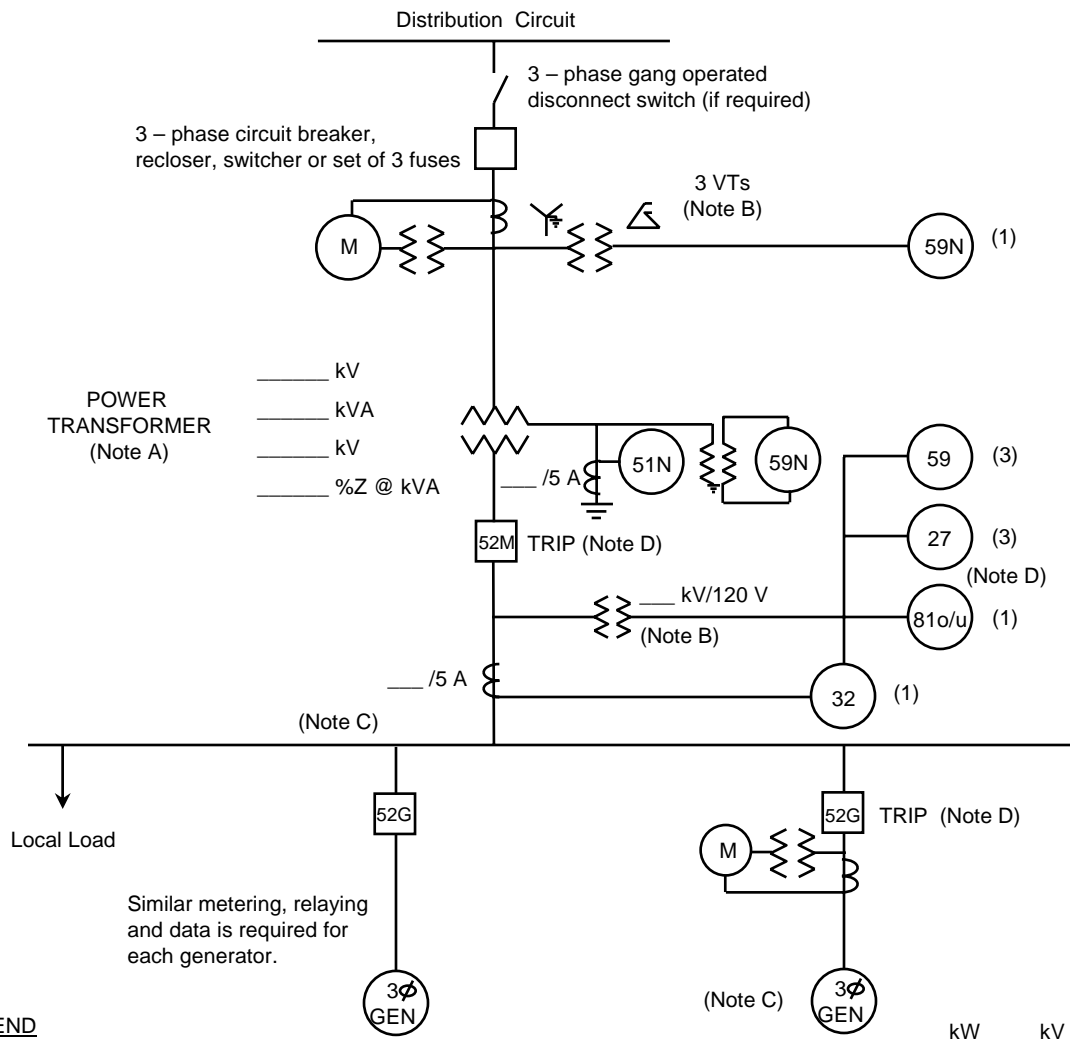

LEGEND

- 27 Undervoltage
- 32 Reverse Power (not required for sellback)
- 51N Neutral overcurrent (required for grounded secondary)
- 59 Overvoltage
- 59N Zero sequence overvoltage (assuming ungrounded secondary on power transformer)
- 81o/u Over/Underfrequency

NOTES

- A) See technical requirements for permissible connection configurations and protection. Transformer connections proposed shall be shown on the one-line diagram by the Project Developer. Transformer connection and secondary grounding to be approved by Utility.
- B) Protection alternatives for the various acceptable transformer connections are shown. Only one protection alternative will ultimately be used, depending on the actual transformer winding connections. VTs for 59, 27, 81o/u and 32 are shown connected on the primary (Project side) of the power transformer, but may instead be connected on the secondary (Utility side). VTs are required on the secondary of the power transformer if a 59N is required for an ungrounded secondary connection. IEEE std 1547 requirements for voltage and frequency must be met at the PCC. IEEE Std. 1547 permits the VTs to be connected at the point of generator connection in certain cases.
- C) Main breaker protection, generator protection and synchronizing equipment are not shown.
- D) Trip of all 52G breakers or the 52M breaker is acceptable, depending upon whether the Project Developer wants to serve its own isolated load after loss of Utility service.

INVERTER-TYPE GENERATORS - AGGREGATE \geq 30 kW, BUT < 150 kW**INTERCONNECTION APPLICATION DATA FOR: _____****PROVIDED BY: _____ DATE: _____**

Instructions: Attach data sheets as required. Indicate in the table below the page number of the attached data on which the requested information is provided.

General Information

Item No	Data Description	Attached Page No
1	Flow-back or Non-Flow-back	
2	Project Type (Base load, peaking, intermediate, other)	
3	Site Plan	
4	Simple One-Line Diagram(s) for Project and Project Load	
5	Detailed One-Line Diagram(s) for Project	
6	Energization Date for Project Interconnection Facilities	
7	First Parallel Operation Date for Testing	
8	Project Commercial Operation Date	
9	Estimated Project Cost	

The following information on these system components shall appear on the preliminary One-Line Diagram, including manufacturer make and model for the items listed below:

- Breakers - Rating, location and normal operating status (open or closed)
- Buses - Operating voltage
- Capacitors - Size of bank in kVAR
- Current Transformers - Overall ratio, connected ratio
- Fuses - normal operating status, rating (Amps), type
- Generators - Capacity rating (kVA), location, type, method of grounding
- Grounding Resistors - Size (ohms), current (Amps)
- Isolating transformers - Capacity rating (kVA), location, impedance, voltage ratings, primary and secondary connections and method of grounding
- Potential Transformers - Ratio, connection
- Reactors - Ohms/phase
- Relays - Types, quantity, IEEE device number, operator lines indicating the device initiated by the relays.
- Switches - Location and normal operating status (open or closed), type, rating
- Tagging Point - Location, identification

INVERTER-TYPE GENERATORS - AGGREGATE \geq 30 kW, BUT < 150 kW

INTERCONNECTION APPLICATION DATA FOR: _____

PROVIDED BY: _____ **DATE:** _____

Instructions: Attach data sheets as required. Indicate in the table below the page number of the attached data (manufacturer's data where appropriate) on which the requested information is provided. Provide one table for each unique generator.

Electric Generator(s) at the Project:		Generator No _____
Item No	Data Description	Attached Page No
1	Generator Type (Inverter)	
2	Generator Nameplate Voltage	
3	Generator Nameplate Watts or Volt-Amperes	
4	Generator Nameplate Power Factor (pf)	
5	Short Circuit Current contribution from generator at the Point of Common Coupling (single-phase and three-phase)	
6	National Recognized Testing Laboratory Certification	
7	Written Commissioning Test Procedure	

APPENDIX D

INTERCONNECTION STUDY AGREEMENT

[Utility]
[Project]
Interconnection Study Agreement for
Generator Interconnection
with Aggregate Project Output of 30 kW or More, but Less than 150 kW

WHEREAS, proposals to construct or upgrade a Project which will be operated in parallel with and interconnected with [Utility's] ("Utility") electric system must be reviewed by the Utility to determine how it will impact the Utility's electric system.

WHEREAS, on _____ Utility received from _____ ("Project Developer") a Generator Interconnection Application.

WHEREAS Utility has determined that an Interconnection Study is necessary to determine whether the Utility electric system can accommodate the requested interconnection.

NOW, THEREFORE, in consideration of the mutual covenants and agreements herein set forth, the Utility and the Project Developer agree as follows:

1. The Utility shall complete an Interconnection Study in accordance with the Utility's Generator Interconnection Requirements and this Agreement.
2. The Utility is permitted by the Michigan Public Service Commission to charge the Project Developer for an Interconnection Study. The charges shall not exceed the lesser of either of the following:
 - (a) 5% of the estimated total cost of the Project
 - (b) \$10,000

The Utility shall not charge the Project Developer if the Project's aggregate export capacity is less than 15% of the line section peak load and the Project does not contribute more than 25% of the maximum short circuit current at the point of interconnection. The Project Developer will be billed for the cost of the Interconnection Study at the conclusion of the Interconnection Study.

3. The Project Developer is to return this executed Interconnection Study Agreement to the Utility as soon as possible. The interconnection process will not proceed until the fully executed Interconnection Study Agreement is received .
4. The Utility shall supply a copy of the completed Interconnection Study to the Project Developer.
5. Any notice or request made to or by either Party regarding this Agreement shall be made to the representative of the other Party, or its designated agent, as indicated below.

Utility

Project Developer

Name _____

Company _____

Address 1 _____

Address 2 _____

IN WITNESS WHEREOF, the Parties have caused this Interconnection Study Agreement to be executed by their respective authorized officials.

By:

By:

(Signature)

(Signature)

(Typewritten or Printed Name)

(Typewritten or Printed Name)

Title

Title

Date

Date

APPENDIX E

**INTERCONNECTION AND OPERATING
AGREEMENT**

**Each Utility will use its own form for the
Interconnection and Operating Agreement.**

INTERCONNECTION AND OPERATING AGREEMENT

This Interconnection and Operating Agreement (“Agreement”) for the facility located at _____, in the City of _____, Michigan, is entered into this _____ day of _____, 200__ by and between Wisconsin Electric Power Company, a Wisconsin corporation authorized to do business in Michigan and doing business as We Energies, (“the Utility”) and _____ (the “Project Developer”). The Utility and the Project Developer are hereinafter collectively referred to as the “Parties” and individually as a “Party”.

RECITALS

WHEREAS, the Utility is the owner of the electric distribution system serving _____ (“Utility Distribution System”); and

WHEREAS, Project Developer desires to install a generation facility or energy storage device including related interconnection equipment (the “Project”) and to interconnect the Project to the Utility’s distribution system; and

WHEREAS, the Utility has previously reviewed and approved the Project Developer’s Interconnection Application dated _____, and supporting materials (the “Application”). The completed Application is attached as Exhibit 1 and incorporated into this Agreement; and

WHEREAS, Project Developer wishes to interconnect the Project to the Utility’s distribution system and the Utility is willing to permit such interconnection subject to the terms and conditions as set forth in the Michigan Electric Utility Generator Interconnection Standards; Mich. Admin. Code R 460.481 through 460.489; the completed Application approved by the Utility; and this Agreement; and

WHEREAS, the Parties have agreed to execute this mutually acceptable Interconnection Agreement in order to provide interconnection service to the Project Developer, and to define the continuing rights, responsibilities, and obligations of the Parties with respect to the use of certain of their own and the other Party’s property, assets, and facilities.

NOW, THEREFORE, in consideration of their respective commitments set forth herein, and intending to be legally bound hereby, the Parties covenant and agree as follows:

Section 1. Design Requirements

1.1 The Project Developer’s facility shall be installed in compliance with Mich. Admin. Code R 460.481 through 460.489 as well as the Michigan Electric Utility Generator Interconnection Requirements, which were approved by the Michigan Public Service Commission on August 10, 2004, both of which may be amended from time to time. Those interconnection requirements are attached as Exhibit 2 and incorporated into this Agreement.

1.2 All Utility Costs associated with making modifications to its distribution system will be paid by the Project Developer.

1.3 Any new line construction to connect the Project to the Utility’s electric system will be undertaken by the Utility at the Project Developer’s expense.

Section 2. Project Developer's Representations and Warranties

2.1 The Project Developer represents and warrants that:

- a. The Project is fully and accurately described in the Application;
- b. All information in the Application is true and correct;
- c. The Project has been installed to the Project Developer's satisfaction;
- d. Project Developer has been given warranty information and an operational manual for the facility;
- e. Project Developer has been adequately instructed in the operation and maintenance of the facility.
- f. Project Developer has read and understands the Interconnection Agreement and all applicable Exhibits and Attachments.
- g. Project Developer has had the Interconnection Process explained to him by a Utility representative.

Section 3 Indemnification

3.1 Each Party to this Agreement shall indemnify, hold harmless and defend the other Party, its officers, directors, employees and agents from and against any and all claims, suits, liabilities, damages, costs, and expenses (including without limitation, reasonable attorney's and expert witness fees) for damage to property, or injury to, or death of, any individual, including the employees, officers, directors and agents of the indemnified Party or any other third-parties, to the extent caused wholly or in part by the negligence or the intentional wrongdoing of the indemnifying Party.

3.2 Notwithstanding anything in this section or in any other provision of this Agreement to the contrary, the liability of each Party to this Agreement shall be limited to direct actual damages, and all other damages at law or in equity are hereby waived. Under no circumstances shall a party be liable to the other Party, whether in tort, contract or other basis in law or equity for any special, indirect, punitive, exemplary, or consequential damages including lost profits.

3.3 Project Developer and the Utility's indemnification obligations under this section and the limits upon their respective liability shall continue in full force and effect notwithstanding the expiration or termination of this Agreement with respect to any event or condition giving rise to an indemnification obligation that occurred prior to such expiration or termination.

Section 4. Discontinued Operations

4.1 The Project shall discontinue parallel operation and perform necessary switching when requested by the Utility for any of the following reasons:

- a. When public safety is being jeopardized.
- b. During voltage or loading problems, system emergencies, or when abnormal sectionalizing or circuit configuration occurs on the Utility system;
- c. During scheduled shutdowns of Utility equipment that are necessary to facilitate maintenance or repairs. Any such scheduled shutdowns shall be coordinated with the Project Developer.
- d. In the event there is demonstrated electrical interference to the Utility's customers, suspect to be caused by the Project, and such interference exceeds then current system standards, the Utility reserves the right, at the Utility's initial expense to install special test equipment as may be required to perform a disturbance analysis and monitor the operation and control of the project to evaluate the quality of power produced by the project. In the event

no standards exist than the applicable tariffs and rules governing electric service apply. If the project is proven to be the source of interference and that interference exceed the Utility's standard or generally accepted industry standards, than it shall be the responsibility of the Project Developer to eliminate the interference problem and to reimburse the Utility for the costs of the disturbance monitoring installation, removal, and analysis excluding the cost of the meters or other special testing equipment.

- e. When either the Project or its associated synchronizing and protective equipment is demonstrated by the Utility to be improperly maintained so as to present a hazard to the Utility system or its customers.
- f. Whenever the Project is operating isolated with other Utility customers for whatever reason.
- g. Whenever the Utility notifies the Project Developer in writing of a claimed non-safety related violation of the Interconnection Agreement and the Project Developer fails to remedy the claimed violation within ten (10) working days of notification, unless within that time the Project Developer either:
 - (i) Files a complaint with the Michigan Public Service Commission seeking resolution of the dispute; or
 - (ii) The Project Developer and Utility agree in writing to a different procedure.

Section 5. Metering

5.1 The Utility will own, operate and maintain all required billing metering equipment at the Project Developer's expense.

5.2 The Project Developer shall provide authorized employees and agents of the Utility access to the premises at all times to install, turn on, disconnect, inspect, test, read, repair, or remove the metering equipment. The Project Developer may, at its option, have a representative present to witness this work.

Section 6. Communication Circuits

6.1 The Project Developer is responsible for ordering and acquiring the telephone circuits required for the Project's interconnection. The Project Developer will assume all installation, operating, and maintenance costs associated with the telephone circuit, including the monthly charges for the telephone line and any rental equipment required by the local telephone provider.

6.2 At the Utility's discretion, the Utility may select an alternative communication method, such as wireless communication.

6.3 Regardless of the method, the Project Developer will be responsible for all costs associated with materials and installation, whereas the Utility will be responsible to define the specific communication requirements.

6.4 The Utility will cooperate and provide Utility information necessary for the proper installation of telephone circuits upon Project Developer's written request.

6.5 All telephone circuits, both voice and data, must be analog circuits.

Section 7. Amendments

7.1 Any amendment or modification to this Agreement must be in writing and executed by the Project Developer and the Utility.

7.2 The failure of the Project Developer or the Utility to insist on performance by the other Party of any provision of this Agreement shall not waive the right of the Party who failed to insist on performance to enforce the same provision at a later time.

Section 8. Term

8.1 This Agreement shall become effective immediately upon the execution by the Parties and shall continue in effect until terminated by any of the following:

- a. Mutual written agreement of the Parties;
- b. Abandonment or removal of the facility by the Project Developer;
- c. By the Utility pursuant to Section 4 of this Agreement; or
- d. By Project Developer upon thirty (30) working days prior written notice given to the Utility.

Section 9. Successors and Assigns

9.1 The Project Developer shall not assign its rights and obligations under this Agreement in whole or in part without the prior written consent of the Utility, which consent shall not unreasonably be withheld or unduly delayed.

9.2 The Utility may withhold its consent to any proposed assignment if the proposed assignee fails to assume the obligations of the Project Developer under this Agreement in writing.

9.3 The Utility shall have the right to assign this Agreement in whole upon written notification to the Project Developer.

9.4 This Agreement shall be binding upon the personal representatives, heirs, successors, and permitted assigns of the respective Parties.

Section 10. Agency

10.1 No agency or partnership is created with the interconnection of the Project Developer's facility.

Section 11. Insurance

11.1 Specified Coverage. As of the date of this Agreement, Project Developer or its contractors and subcontractors, as applicable, shall maintain liability insurance equal to or greater than the following amounts, per occurrence. The Project Developer shall name the Utility as an additional insured party in the liability insurance policy.

11.1.1 For Projects 30 kw and less, the minimum liability insurance coverage shall be \$300,000.00

11.1.2 For Projects more than 30 kw but less than 750 kw, the minimum liability insurance coverage shall be \$1,000,000.00

11.1.3 For Projects more than 750 kw but less than 2 MW, the minimum liability insurance coverage shall be \$2,000,000.00

11.1.4 For Projects greater than 2 MW, the minimum liability insurance coverage shall be negotiated by the Parties.

11.2 Each Party waives all rights against the other Party and such other Party's agents, officers, directors and employees for recovery of damages to the extent such damages are covered by any of the insurance required above. However, the liability assumed in this section by Project Developer and Utility shall not be limited by any other commercial terms of this Agreement.

11.3 Insurance Certificates.

Project Developer shall furnish Utility with duly executed certificates of insurance certifying that such insurance has been provided and that the insurance companies will give Utility thirty (30) days prior written notice of any material change in, or cancellation of, such insurance coverage.

Such certificates shall also specify the dates when such insurance commences and expires. Certificates should be delivered to Utility at the address set forth in the Generator Interconnection Requirements, attached hereto as Exhibit 2.

Project Developer agrees that such insurance shall be maintained throughout the entire term of this Agreement. New certificates shall be provided within two weeks of the renewal date of any expiring insurance coverage giving evidence of continuing coverage.

The failure of the Utility to obtain evidence of such insurance from the Project Developer shall not be deemed to be a waiver by the Utility, and the Project Developer shall remain under continuing obligation to maintain the insurance coverage.

Section 12 Event of Default and Remedies.

12.1 An Event of Default shall occur upon (i) a failure by a Party to pay any amount due hereunder when due or (ii) a failure by a Party to perform any other obligation under this Agreement, provided the following:

12.1.1 Said failure has a material adverse impact on the non-defaulting Party;

12.1.2 Said failure has not been cured by the defaulting Party within thirty (30) days after receiving written notice of the default from the other Party, which notice sets forth in reasonable detail the nature of the default; and

12.1.3 In the case of a material failure, other than a failure to pay any amount due hereunder when due, that is not reasonably capable of being cured within the aforesaid thirty (30) day period, the defaulting Party shall have an additional period of one-hundred and fifty (150) days to cure the default, *provided* the defaulting Party commences a cure within such thirty (30) day period and thereafter diligently pursues such cure to completion within such additional period.

12.2 Upon the occurrence of an Event of Default, if the defaulting Party fails to cure the default within the period described above, the non-defaulting Party shall have the following rights:

12.2.1 to terminate this Agreement by written notice to the defaulting Party;

12.2.2 to suspend performance of its obligations and duties hereunder upon written notice to the defaulting Party; and

12.2.3 to pursue any other remedy given under this Agreement or which is now or hereafter existing at law or in equity or otherwise.

Section 13 Force Majeure

13.1 If either Party is rendered unable, wholly or in part, by Force Majeure to carry out its obligations under this Agreement, it is agreed that, upon such Party giving notice and reasonably full particulars of such Force Majeure by telephone, to be confirmed in writing, to the other Party as soon as possible after the occurrence of the cause relied upon, the obligations of the Party giving such notice, other than to make payments accrued hereunder, so far as they are affected by such Force Majeure, shall be suspended during the continuance of any inability so caused but for no longer period. Such cause shall, as far as possible, be remedied within thirty (30) days after the occurrence; provided, however, that in the case the cause relied upon cannot reasonably be cured within the thirty (30) day cure period, the Party giving notice shall have additional time to cure the cause relied upon if such party commences to cure the cause within such thirty (30) day cure period, it diligently pursues such cure, and such cause is capable of being cured by the Party giving notice within no more than one hundred twenty (120) days after the occurrence of the cause relied upon. If the event of Force Majeure continues for more than one hundred twenty (120) days, the Party not invoking may terminate this Agreement by notice to the other Party delivered within one hundred fifty (150) days after the commencement of the event of Force Majeure, provided that the event of Force Majeure has not terminated as of the date such notice is received. In the event the Force Majeure relied upon has not terminated as of the date such notice is received, this Agreement will terminate on the date of receipt of such notice of termination and neither Party shall have any further obligation under this Agreement, except such termination shall not relieve either Party of the obligation to pay to the other Party amounts then owing.

IN WITNESS WHEREOF, Project Developer and Utility have executed this Agreement as of the year and date first set forth above.

WISCONSIN ELECTRIC POWER COMPANY

Dated: _____

BY: _____

TITLE: _____

PROJECT DEVELOPER

Dated: _____

BY: _____

TITLE: _____

APPENDIX F

CONTACT

We Energies

[Attn: Jason Kollwelter](#)

231 W. Michigan St. - P318

Milwaukee, WI 53203

920-563-1249